

PowerWalker Maintenance Bypass Switch Module

Quick Guide

V. 1.0

1. Introduction

The module is used as an external maintenance bypass switch to provide continuous power without shutting down the connected loads during UPS scheduled maintenance or battery replacement. It's perfect to use in conjunction with 3-phase in/3-phase out 10K/20KVA UPS.

Wall-mounting the Unit

The module can be wall-mounted to the wall. Please follow below chart for installation.

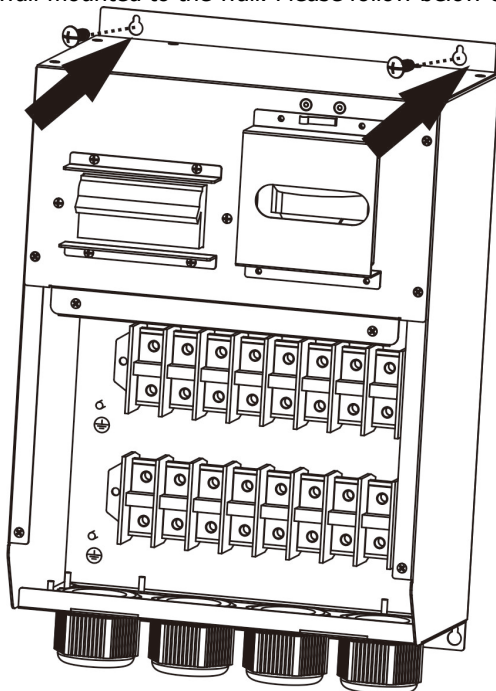

2. Product Overview

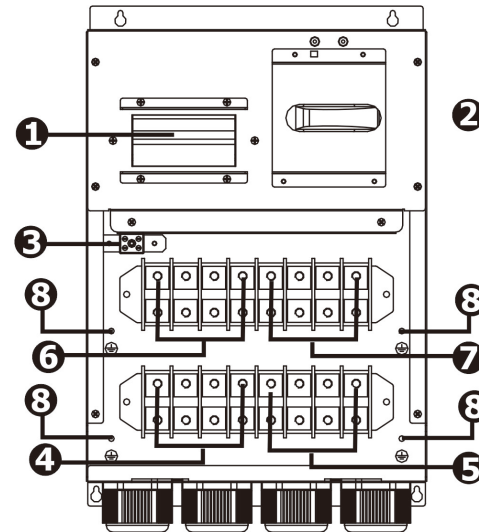

- ❶ UPS input breaker
- ❷ Maintenance bypass switch
- ❸ Control output signal connector
- ❹ Output terminal
- ❺ Utility input terminal
- ❻ UPS output terminal
- ❼ UPS input terminal
- ❽ Grounding terminal

3. Installation and Operation

Inspection

Unpack the package and check the package contents. The shipping package contains:

- Maintenance bypass switch module x 1
- Quick guide x 1
- Control signal cable x 1

NOTE: Before installation, please inspect the unit. Be sure that nothing inside the package is damaged during transportation. Do not turn on the unit and notify the carrier and dealer immediately if there is any damage or lacking of some parts. Please keep the original package in a safe place for future use.

Initial Setup

The Installation and wiring must be performed in accordance with the local electric laws/regulations and execute the following instructions by professional personnel.

1) Make sure the mains wire and breakers in the building are enough for the rated capacity of UPS to avoid the hazards of electric shock or fire.

NOTE: Do not use the wall receptacle as the input power source for the UPS, as its rated current is less than the UPS's maximum input current. Otherwise, the receptacle may be burned and destroyed.

2) Switch off the mains switch in the building before installation.

3) Turn off and shut down the connected UPS.

4) Prepare wires based on the following table:

UPS Model	Wire Spec (AWG)
3P/3P 10K/10KL	8
3P/3P 20K/20KL	6

NOTE 1: The cable for 10K(L) should be able to withstand over 63A current. It is recommended to use 8AWG or thicker wire for safety and efficiency.

NOTE 2: The cable for 20K(L) should be able to withstand over 100A current. It is recommended to use 6AWG or thicker wire for safety and efficiency.

NOTE 3: The selections for color of wires should be followed by the local electrical laws and regulations.

5) Remove the terminal block cover on the rear panel of the module. Then connect the wires according to the following terminal block diagrams:

Connect UPS and External Maintenance Bypass Switch Module

Remove the terminal block cover on the rear panel of the module. Then connect output terminals of UPS to output terminals of switch module. Connect utility input terminals of UPS to UPS input terminals of switch module. Connect signal slots of UPS and switch module with control signal cable attached to the package. Refer to blew chart for wiring connection:

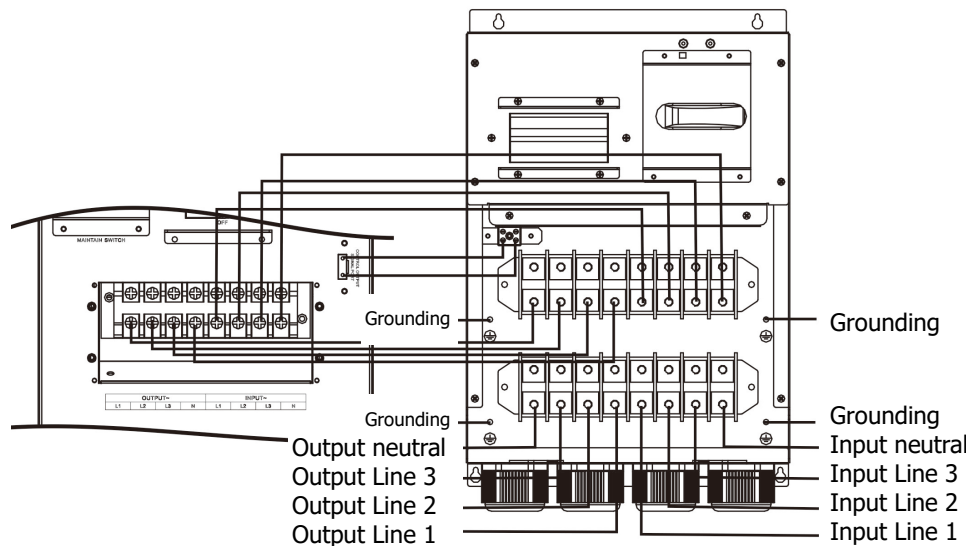

NOTE : Make sure that the wires are connected tightly with the terminals. Put the terminal block cover back to the rear panel.

4. Operation

Transfer to Maintenance Bypass

To transfer to maintenance bypass from UPS, follow the below steps:

Step 1: Press "OFF" button of UPS unit to transfer to bypass mode.

Step 2: Open the maintenance switch cover. If step 1 is not executed first, then UPS unit will transfer to bypass mode automatically with control output signal connection when opening the maintenance switch cover.

Step 3: Transfer rotary switch to "BPS" position and switch off UPS input breaker on the module. Then, all devices are directly powered by utility and there is no current through the UPS. The output and input of UPS are isolated from the system. You may now service or maintain the UPS by shutting down the batteries of UPS.

Transfer to UPS Protection

After maintenance service is done, follow below steps to transfer back to UPS operation.

Step 1: Switch on the input breaker of the module and reconnect UPS battery input breaker. Then UPS will enter to bypass mode.

Step 2: Transfer rotary switch to "UPS" position. Then, all devices are powered by utility through UPS bypass mode.

Step 3: Close back maintenance switch cover and press "ON" button of UPS unit. Then, all devices are protected by the UPS.

NOTE: If maintenance will be executed in another place, before removing the UPS and the module, please follow steps of "Transfer to Maintenance Bypass" and then disconnect all wires between UPS and the module for complete isolation.

5. Specification of Critical Components

Model		For 10K UPS	For 15K UPS	For 20K UPS
Parameter		Max.	Max.	Max.
Input breaker (each pole)	Current	63 A	100 A	100 A
	Voltage	400 V	400 V	400 V
Bypass switch	Current	63 A	100 A	100 A
	Voltage	690 V	690 V	690 V
Input/Output terminal	Current	60 A	100 A	100 A
	Voltage	600 V	600 V	600 V